













Laser Triangulation Displacement Sensors





-  **Laser Line averages across shiny metallic or structured surfaces**
-  **Four models with measuring ranges from 2mm to 50mm**
-  **Compact design with integrated controller**
-  **Real Time Surface Compensation**
-  **Adjustable measuring rate up to 2.5kHz**
-  **Analogue (U/I) and digital output**
-  **Adjustable filter functions (firmware)**
-  **High flex cables for dragchain or robot use**
-  **Calibration certificate included**
-  **Configuration via software www.micro-epsilon.com/download**

Designed for shiny and rough surfaces where high accuracy measurements are required. The optoNCDT 1700LL provides precision accuracy with an integrated controller. The laser spot is optically enlarged to make an oval point thus reducing the physical interference making measurements on rough surfaces considerably easier to perform. The 1700LL combines the advantages of both the 1700 and the 2200LL series offering high precision and flexibility with a compact sensor size.

optoNCDT 1700LL (2/10/20/50mm)

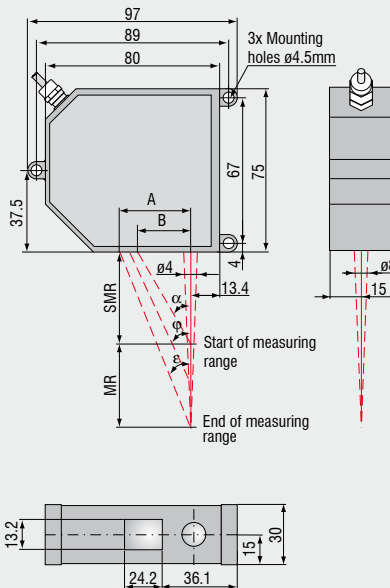

MR	SMR	α	φ	ϵ	A	B
2	24	35°	40°	44.8°	25.8	16.8
10	30	34.3°	35.2°	35.6°	28.7	20.5
20	40	28.8°	27.5°	26.7°	30.1	22.0
50	45	26.5°	23.0°	18.3°	31.5	22.5

Connector (sensor side)
Article Number: 0323243

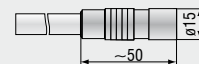

Connector (sensor cable)
Article Number: 0323272

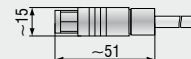

(Dimensions in mm, not to scale. All CAD files are available online.)

Model		ILD1700-2LL	ILD 1700-10LL	ILD 1700-20LL	ILD 1700-50LL
Measuring range		2mm	10mm	20mm	50mm
Start of measuring range		24mm	30mm	40mm	45mm
Midrange		25mm	35mm	50mm	70mm
End of measuring range		26mm	40mm	60mm	95mm
Linearity	FSO	2µm ≤0.1%	8µm	16µm ≤0.08%	40µm
Resolution ¹⁾ (at 2.5kHz without averaging)		0.1µm	0.5µm	1.5µm	3µm
Measuring rate		2.5kHz / 1.25kHz / 625Hz / 312.5Hz (adjustable)			
Light source		semiconductor laser <1mW, 670nm (red)			
Permissible ambient light	at 2.5kHz	10,000lx			
Laser safety class		class 2 acc. DIN EN 60825-1 : 2001-11			
Spot diameter	SMR	85 x 240µm	120 x 405µm	185 x 485µm	350 x 320µm
	MMR	24 x 280µm	35 x 585µm	55 x 700µm	70 x 960µm
	EMR	64 x 400µm	125 x 835µm	195 x 1200µm	300 x 1940µm
Temperature stability ²⁾		0.025% FSO/°C	0.01 % FSO/°C		
Operation temperature		0 ... +50°C			
Storage temperature		-20 ... +70°C			
Output	measurements	selectable: 4 ... 20mA / 0 ... 10V / RS 422 / USB (optional with cable PC1700-3/USB)			
	switching outputs	1 x error or 2 x limit (each programmable)			
Switch Input		laser ON-OFF / zero			
Operation		via touch screen on sensor or via PC with ILD 1700 tool			
Power supply		24VDC (11 ... 30VDC), max. 150mA			
Electromagnetic compatibility (EMC)		EN 61000-6-3 EN 61000-6-2			
Sensor cable length (with connector)		0.25m (integrated cable with connector) option: 3m or 10m			
Synchronisation		possible for simultaneous or alternating measurements			
Protection class		IP 65			
Vibration		2g / 20 ... 500Hz			
Shock		15g / 6ms			
Weight (with 0.25m cable)		~ 550g			

FSO = Full Scale Output All specifications apply for a diffusely reflecting white ceramic target
 SMR = Start of measuring range MMR = Midrange EMR = End of measuring range

¹⁾ for measurements against high glossy surfaces (targets), resolution depends on the material

²⁾ based on digital output

Custom Sensor Modifications

For applications where the above standard sensors do not meet your requirements, it may be possible to supply a sensor with modified specification. Please contact us for further information.

Options

- Non standard measuring range and stand off
- Custom housing or mounting geometry
- Non standard signal interfaces
- Special cable length of electrical connector
- 90° beam deflection
- Vacuum suitability
- Reduced mass
- Increased shock and vibration resistance

High performance sensors made by Micro-Epsilon



Sensors and systems for displacement, position and dimension

Eddy current sensors
Optical and laser sensors
Capacitive sensors
Inductive sensors
Draw-wire sensors
Optical micrometers
2D/3D profile sensors
Image processing



Sensors and measurement devices for non-contact temperature sensors

Online instruments
Handheld devices

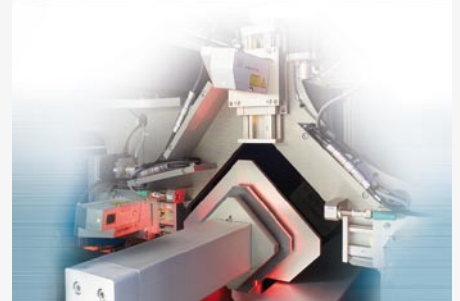

Measuring systems for quality control

for plastic and film
for tire and rubber
for web material
for automotive components
for glass